



MISSION COMMAND TRAINING PROGRAM "DECISIVE VICTORY!"

UNCLASSIFIED

MCTP Overview Brief



Mission Command Training Program (MCTP) Overview Brief







WARFIGHTERS!



As of 28 JUL 20



-  **Mission**
-  **Commander’s Intent**
-  **Who We Are**
-  **Where We’ve Been**
-  **MCTP Position Improvement**
-  **Warfighter as a Doctrinal Test**
-  **MCTP Design and Delivery**
-  **Warfighter Event Lifecycle**
-  **Exercise Design**
-  **Warfighter Best Practice “BIG 8”**
-  **FY 20-21 Exercise Calendars**
-  **Discussion**





The Mission Command Training Program is the premier deployable combat training center for **implementing**, **observing**, **coaching**, and **facilitating** collective training opportunities and leadership experiences for Commanders and staffs to **plan**, **prepare**, **fight**, and **win** during **Large Scale Combat Operations**.

MCTP Contributions to the Army

- ✓ Readiness
 - METL Focus
 - Training Objectives
- ✓ Leader Development
- ✓ Building Expeditionary Capabilities

CORPS MISSION ESSENTIAL TASK LIST	
	MET 1: Conduct Shaping Operations for Corps (71-8-1270)
	MET 2: Conduct Forcible Entry Operations for a Corps (71-8-1340)
	MET 3: Conduct Campaign and Major Land Combat Operations for Corps (71-8-7000)
	MET 4: Conduct Attack for Corps (71-8-7120)
	MET 5: Conduct Defense for Corps (71-8-7222)
	MET 6: Conduct Force Protection for Corps (71-8-7300)

DIVISION MISSION ESSENTIAL TASK LIST	
	MET 1: Conduct Forcible Entry Operations for a Division (71-7-1340)
	MET 2: Conduct Area Security for Divisions (71-7-6500)
	MET 3: Conduct Movement to Contact for Divisions (71-7-7110)
	MET 4: Conduct Attack for Divisions (71-7-7120)
	MET 5: Conduct Defense for Divisions (71-7-7222)
	MET 6: Conduct Force Protection for Divisions (71-7-7300)





PURPOSE: WINNING MATTERS! Our number one priority is in line with the Chief of Staff of the Army's number one priority: Our people. As WARFIGHTERS, our primary objective is honorable service as members of a disciplined, trusted, cohesive, and doctrinally sound team. Our team consists of dedicated professionals, Soldiers, civilians, and family members alike, who will train together, learn together, win together, and take care of each other, always.

KEY TASKS:

- 1) Train: One team of military and civilians.
- 2) Communicate: Internally and Externally
- 3) Develop Leaders: Main Effort is our OC/Ts
- 4) Evolve: Modernization and Future Initiatives
- 5) Families: Information sharing and resources

ENDSTATE: MCTP remains the Army's premier combat training center and engine of change for collective training for our Corps, Divisions and Army Service Component Commands. Our people enjoy this unique assessment and follow on leaders want to join our command.





MISSION COMMAND TRAINING PROGRAM

"DECISIVE VICTORY!"

UNCLASSIFIED

MCTP

Who We Are...

Personnel Strength

Military
 Authorized: 454
 Assigned: 415

Army Civilians
 Authorized: 105
 Assigned: 100

HQE-SM: 24
NGSC Full Time: 355
Part Time: 427

Military Assigned by Grade

COL: 14 CPT: 38
 LTC: 84 WO: 36
 MAJ: 174 ENL: 69

As of 20 JUL 20



COL Shane Morgan (JUL 19)
 Commander, MCTP
 Branch: Field Artillery



CSM Michael McKay (JUL 18)
 Command Sergeant Major, MCTP
 Branch: Infantry



Mr. Myron Reineke
 Deputy/Training Program Manager
 Former Chief of Operations Group,
 Operations Group Delta and X-Ray



Mr. Mike McGuire
 Northrop Grumman
 Program Manager

Operations Group Alpha

COL Robert Molinari



Branch: Armor
 Arrived: 15 July 2019
 Expected loss: June 2022
 Previous Assignment: Director, Combat Training Center Directorate

Training Focus:
 Divisions/ Corps/ Army Service Component Command

Operations Group Bravo

COL Chris Moretti



Branch: Field Artillery
 Arrived: 15 July 2019
 Expected loss: July 2022
 Previous Assignment: Chief of Staff, Joint Readiness Training Center

Training Focus:
 Functional and Multi-Functional Brigades
 Focus on Artillery

Operations Group Charlie

COL Tommy Cardone



Branch: Infantry
 Arrived: 16 July 2018
 Expected loss: July 2021
 Previous Assignment: G-3, National Training Center

Training Focus:
 National Guard Brigade Combat Teams and select Functional and Multi-Functional Brigades

Operations Group Delta

COL Michael Manner



Branch: Infantry
 Arrived: 28 May 2019
 Expected loss: July 2022
 Previous Assignment: SAMS Fellow, Instructor, School of Advanced Military Studies

Training Focus:
 Divisions/ Corps/ Army Service Component Command

Operations Group Foxtrot

COL Stuart Smith



Branch: Aviation
 Arrived: 15 July 2019
 Expected loss: June 2022
 Previous Assignment: Director, Collective Training Directorate

Training Focus:
 Functional and Multi-Functional Brigades
 Focus on Aviation

Operations Group Juliet

COL Matt Harmon



Branch: Special Forces
 Arrived: 31 May 2019
 Expected loss: June 2022
 Previous Assignment: Fellow, U.S. Army War College

Training Focus:
 Special Forces Interdependence, Integration, and Interoperability, and Special Forces Headquarters

Operations Group Sierra

COL Jack Shields



Branch: Logistics
 Arrived: 15 July 2019
 Expected loss: July 2022
 Previous Assignment: G4, 1st Infantry Division

Training Focus:
 Sustainment Brigades, Theater Sustainment Commands, and Expeditionary Sustainment Cmds

Operations Group X-Ray

COL Eric Puls



Branch: Aviation
 Arrived: 15 August 2015
 Expected loss: September 2021
 Previous Assignment: Chief Operations Group, Operations Group Foxtrot

Training Focus:
 World Class OPFOR, Exercise Control, Scenario Design, Joint Effects Division, Plans and Operations Systems

USAF 505th CCW, Detachment 1

COL Mike Goodman



Branch: USAF, EC-130H & AC-130H Navigator
 Arrived: 02 July 2018
 Expected loss: 02 July 2021
 Previous Assignment: 608th Air Operations Center

Training Focus:
 Replication of Combined Air Component and Theater Air-Ground echelons

Mission Statement:

The Mission Command Training Program is the premier deployable combat training center for implementing, observing, coaching, and facilitating collective training opportunities and leadership experiences for Commanders and staffs to plan, prepare, fight, and win during Large Scale Combat Operations.



MISSION COMMAND TRAINING PROGRAM
"DECISIVE VICTORY!"

UNCLASSIFIED

Highly Qualified Experts
Senior Mentors

 <p>GEN (R) McKiernan AR ISAF CDR 59 Day</p>	 <p>LTG (R) Hogg AR US MIL REP NATO 130 Day</p>	 <p>LTG (R) Tucker AR CG, First Army 59 Day</p>	 <p>LTG (R) Fridovich SF CG, USASOC 59 Day</p>	 <p>LTG (R) Valcourt FA CG, 8th Army 59 Day</p>	 <p>LTG (R) Buchanan IN CG, USARNORTH 59 Day</p>	 <p>MG (R) Golden AV DCG (O) 8 Army 130 Day</p>
 <p>MG (R) Longo FA DCG 7 Army 130 Day</p>	 <p>MG (R) Richardson LG CG, MSDDC 130 Day</p>	 <p>MG (R) Watson EN Dir-J-3 Ops/Cyber 130 Day</p>	 <p>MG (R) Gronski IN DCG (ARNG), USAREUR 59 Day</p>	 <p>MG (R) Colt AV CG, 1st ARMY Div West 59 Day</p>	 <p>MG (R) Dorman LG CG, 8th TSC 59 Day</p>	 <p>Maj Gen (R) Zobrist AV Cdr, 9 AF 59 Day</p>
 <p>MG (R) Walters MI CG, US Intel CoE 130 Day</p>	 <p>BG (R) Akin LG CG, 3d ESC 130 Day</p>	 <p>BG (R) Laughlin AR DCG (M), 2 ID 130 Day</p>	 <p>BG (R) Novalis AV NATO Corps J3 59 Day</p>	 <p>BG (R) Turner FA DCG, 1st ID 130 Day</p>	 <p>BG (R) Odom IN Dir, DOC-FCC 59 Day</p>	 <p>BG (R) Thompson IN DCG (S), 25th ID 59 Day</p>



UNCLASSIFIED

As of 26 JUN 20



MISSION COMMAND TRAINING PROGRAM

"DECISIVE VICTORY!"

UNCLASSIFIED

MCTP EVOLUTION (1986-2020)

Where We've Been...

2010 (Where we were...)

- ▲ Mission Readiness Exercises
- ▲ BCT COIN Seminars
- ▲ TDA: 403 Military
- ▲ No SOF Operations Group
- ▲ Not Tier 1 Fill per Army Manning Guidance
- ▲ GAAT Scenario Only
- ▲ Minimal Planning Capacity
- ▲ Simulation: Corps Battlefield Simulation (CBS)
- ▲ Static Exercises; not large scale combat operations
- ▲ No Special Technical Operations (STO)

2020 (Where we are now...)

- ▲ Warfighters (Divisions, Corps, plus ASCC exercises)
- ▲ Divestiture of NG BCT WFXs in FY 20
- ▲ TDA: 454 Military
- ▲ 2013: Formation of OPS GRP J
- ▲ 2019 Army Manning Guidance (100% OC/T=318)
- ▲ Caspian, Korea, Baltics Scenarios
- ▲ Centralized Planning Capacity: OPS GRP X
- ▲ 2011 WARSIM; 2021 JLCCTC 9.0 to stimulate MDO
- ▲ Information Warfare Division; STO facility in Lewis & Clark (MDO)
- ▲ Increased Realism: CP displacement, degraded comms, MOPP, EDRE

MANDATE

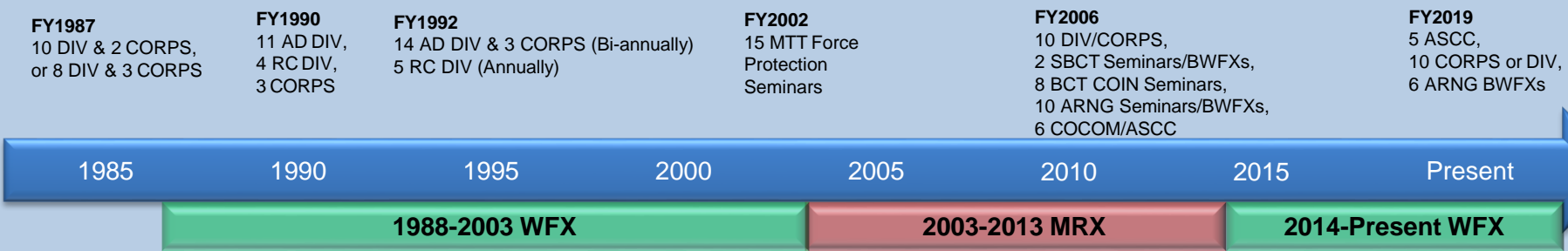

OPERATIONS

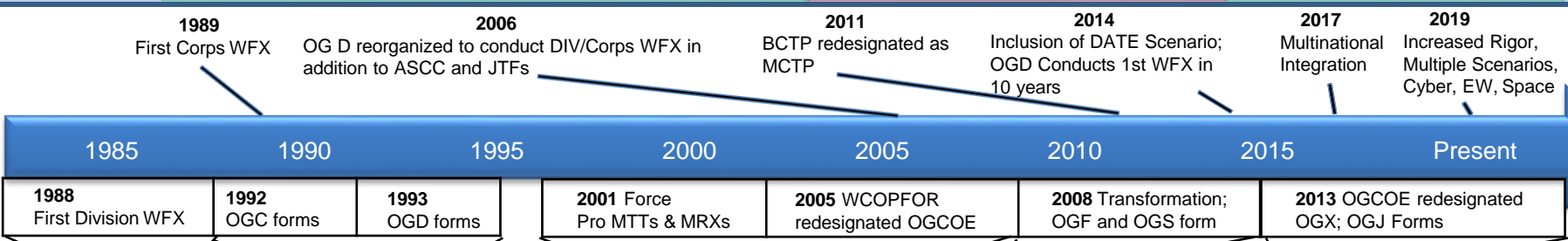

MANNING

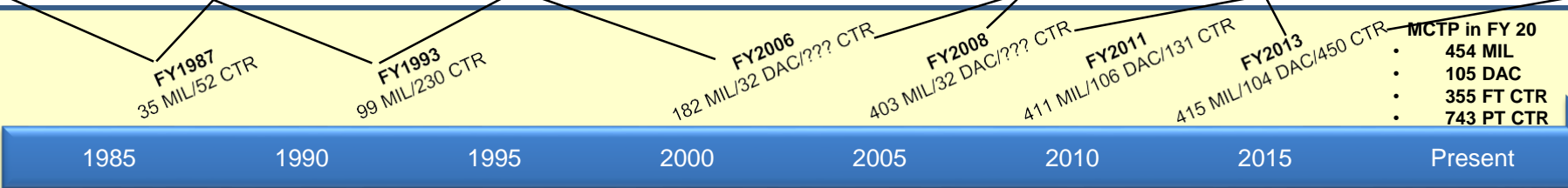

STRUCTURE

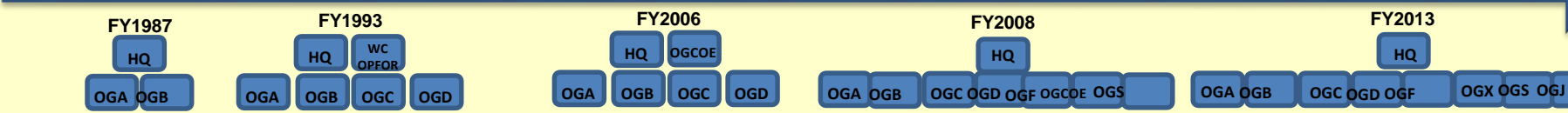



- CPX3 Support (WCOPFOR, HQE-SMs ICW GSC)
- CGSC, DTAC and SAMS Partnership
- Final Exercise Report (FER) Dissemination
- Leader Development Framework
- MCTP Quarterly Newsletter (New)
- AIM2: WFF Alignment and Proponent Lead(s)
- Publish Articles in Professional Journals
- HQE-SM Recruitment and Retention
- Twitter handles for OPS GRPs (Observations)
- MCTP Facebook pages (Soldiers and Families)
- MCTP Recruitment Video
- MCTP History Update (2003-present)
- JROTC Partnership
- Annual Readiness Guidance
- Warfighters Way
- FRG, Morale / Team Building Events

❖ ***Connecting with the Operating Force***

❖ ***Bringing Training to the Soldier***

❖ ***Building Capabilities for Progression***





MISSION COMMAND TRAINING PROGRAM "DECISIVE VICTORY!"

UNCLASSIFIED

WFXs as a Doctrinal Test

Army/ Joint Doctrine;
Emerging Doctrine

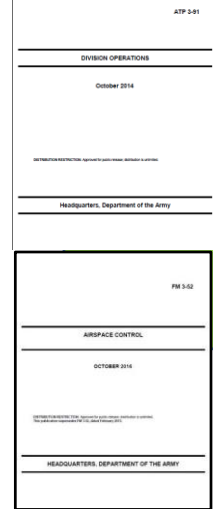

Warfighter Exercise

Mission Command Failure Modes

The Army Operating Concept

MCTP designs Decisive Action focused exercises, incorporating all aspects of the Army Operating Concept to enable units to build METL focused readiness and support leader development through Mission Command

Army's Core Competencies

- Shape the Security Environment
- Strike Threats
- Project National Power
- Coordinate Operations
- Special Operations

MCTP's Decisive Action WFXs support AOC in that it provides and integrates:

- Multi-domain (Land, Air, Maritime and Space)
- Multi-component (Infantry, Cavalry and Stryker)
- Joint Enablers, Joint Functions and S&P
- ASCC Operations (In operations to train/develop/prepare and integrate)
- Comps/EN (As an JTR/JFLC/FC/CS)
- Cooperative (As an integrated multi-subordinate/ENs) within a very complex MOC/CE
- Coalition and Inter Agency Partners
- Fire-fighting (How they interact/prepare within a complex CE)
- INTEC Operations
- CBRE/Intelligence Operations
- Intelligence (Operations/Threat/Space Operations)
- Media

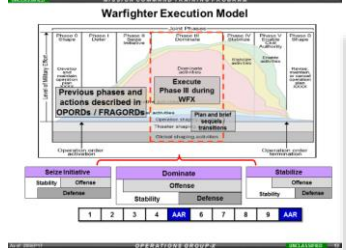

Exercise Trends

- MCTP Exer Trends sent to:
 - FORSCOM
 - DA
 - CALL
 - TRADOC

After Action Reviews

- Two AARs per WFX
- Instrumented
- Unit receives Final Exercise Report

- MCTP Relationship with TRADOC Organizations
- Mission Command COE
 - Maneuver COE
 - Fires COE
 - Aviation COE
 - Cyber COE
 - Intelligence COE
 - Maneuver Support COE
 - CASCOM
 - CALL
 - CADD

Updates to Army/ Joint Doctrine



MCTP uses approved and emerging Joint/Army doctrine to design and control Warfighter Exercises that afford opportunities for stimulating training objectives. OPSGRPs use doctrine to observe, coach, and teach training units; develop informed After Action Reviews, produce Final Exercise Reports; and provide annual observation reports. These processes and products, along with MCTP relationships with TRADOC organizations, aide in the continued development of Army and Joint Doctrine.

UNCLASSIFIED



• **5 x Multi-Echelon, Multi-Component WFXs**

- 1-2 x Corps HQs
- 8-9 x Division HQs
- Approximately 22 x F/MF BDE HQs
- 10 x Sustainment BDE/ESC HQs
- 1-3 x SOF HQs

"MCTP is the Army's primary CTC for Mission Command Training."

Source: AR 350-50 para 1-5 e. (1)

• **5 x Army Service Component Command (ASCC) Exercises**

- US Army Pacific: Combined Command Post Training 20-1
- US Army Central: Lucky Warrior (deferred in FY 20)
- US Army North: Vibrant Response 20
- US Army Europe: DEFENDER 20 (Europe) Command Post Exercise
- US Army Africa: Judicious Response 21 (deferred in FY 20)



• **2 x Army National Guard Brigade WFXs (BWX; ends after FY 20)**

• **Event Life Cycle (ELC)**

- 3 x Planning events per exercise (CDB/IEP, MEP, FEP)
- 1 x Mission Command Training (MCT) seminar per Training Audience

• **Deliverables:**

- Mid Point AAR (MAAR), Final AAR (FAAR), Final Exercise Report (FER)
- Annual Key Observations (CALL) – moving to Semi-Annual in FY21



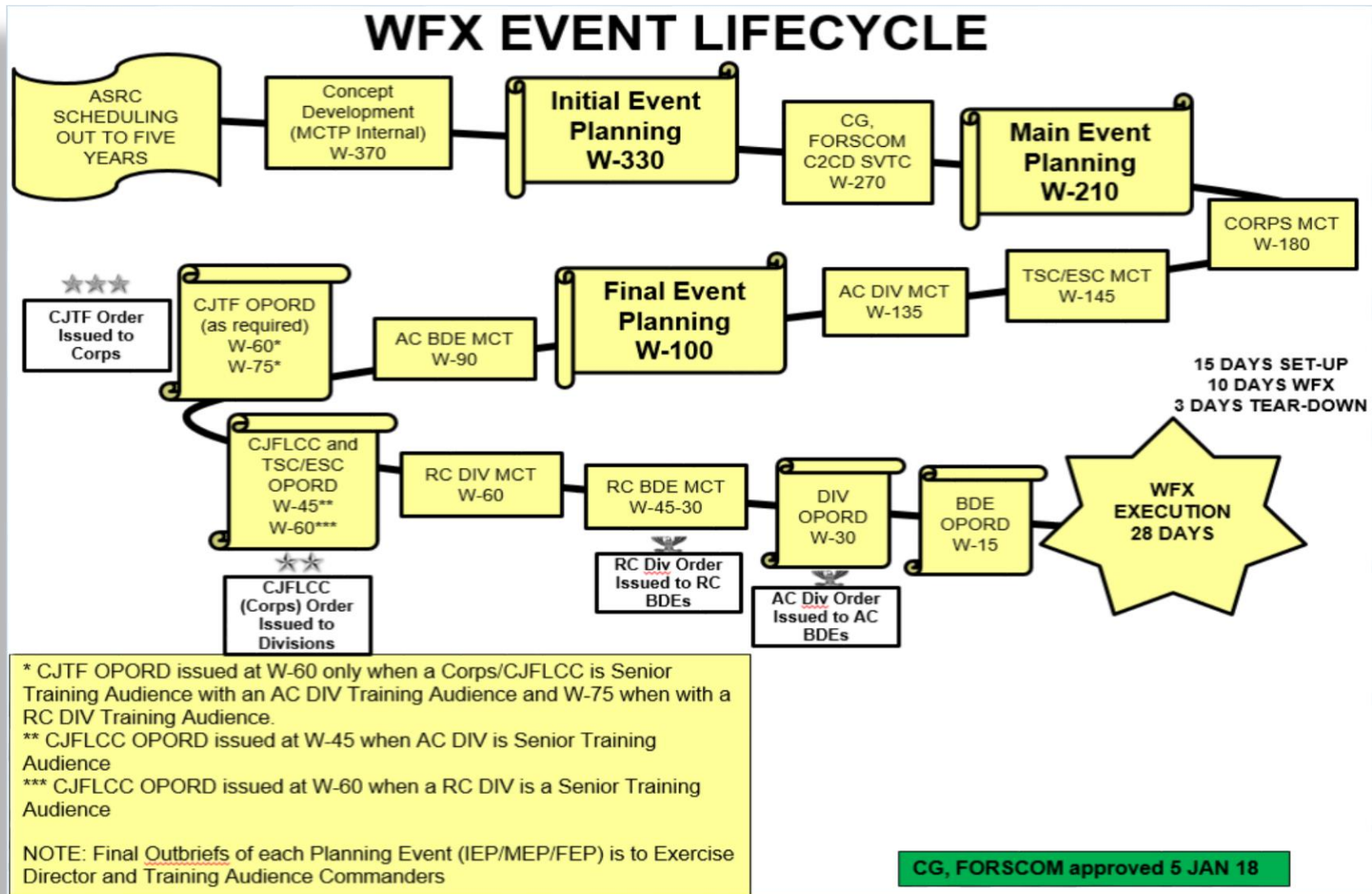



MISSION COMMAND TRAINING PROGRAM "DECISIVE VICTORY!"

UNCLASSIFIED

Exercise Design

Multi-Echelon

Total Army Integration

Joint Context

Unified Action Partners

Multi-National

SOF

SHARP

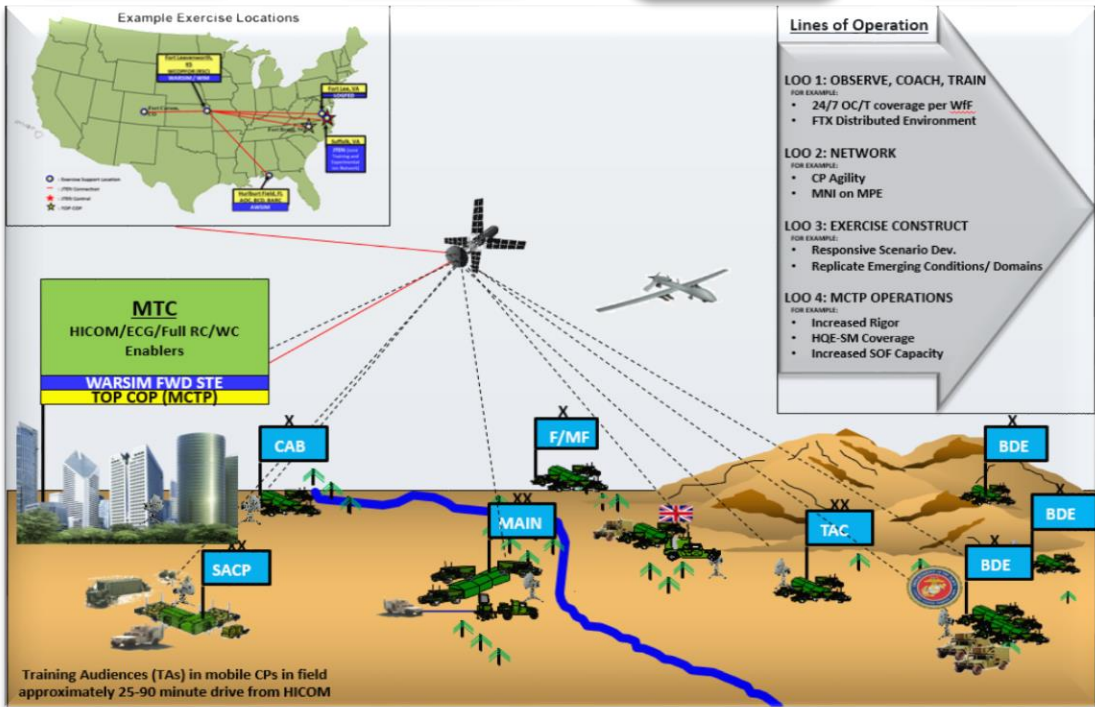

DATE

Counter-WMD

Hybrid Threat

Sustainment

Personnel Recovery

Deployable CPs

Media

Space

Cyber



UNCLASSIFIED



MISSION COMMAND TRAINING PROGRAM
"DECISIVE VICTORY!"

UNCLASSIFIED

WFX Exercise Control Group

Exercise Control Group (ECG) – Plans and controls the exercise based on Exercise Director Guidance

Exercise Control Group (ECG) Leadership

Position	Rank	Description
Exercise Director	LTG/MG	Leads the exercise
HICOM Commander	MG/BG	Commands the HICOM
Deputy Exercise Director	COL	MCTP CDR – Directs the ECG
Chief Controller	COL	COG OG X – Controls the WFX
Chief of Air Power/ Chief Air Controller	Col	505 th DET 1 CDR – Replicates CFACC
Chief of Special Operations Forces (SOF)	COL	COG OG J

Exercise Control Group (ECG) Organizations

Organization	PAX	Description
Plans and Operations/OG X	40	Lead exercise planning and manage ECG battle rhythm
Scenario Design/OG X	40	Create and manage the exercise scenario; develops MSEL injects; Coordinates effects of WCOPFOR; Supervises actions of Adjacent Division and Host Nation Response Cells
Exercise Control/OG X	20	Stimulates the training audiences; Supervises cells and injects MSELs; Supervises HICOM and LOCOM Response/Work Cells
Operations Group (OG)	~80	Train and mentor training audiences; ensures units training objectives are stimulated

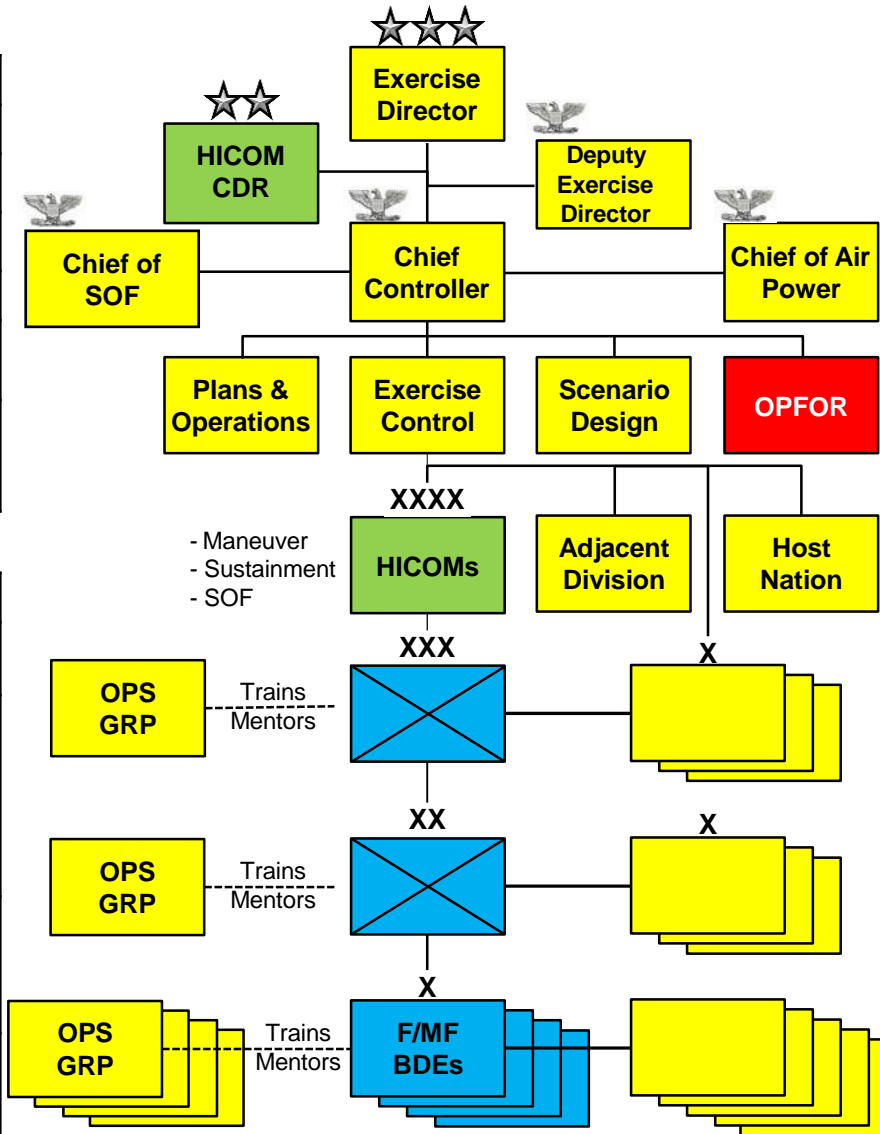

■ Exercise Control Group ■ Training Audience

UNCLASSIFIED



MISSION COMMAND TRAINING PROGRAM

"DECISIVE VICTORY!"

UNCLASSIFIED

WFX Example Troop List

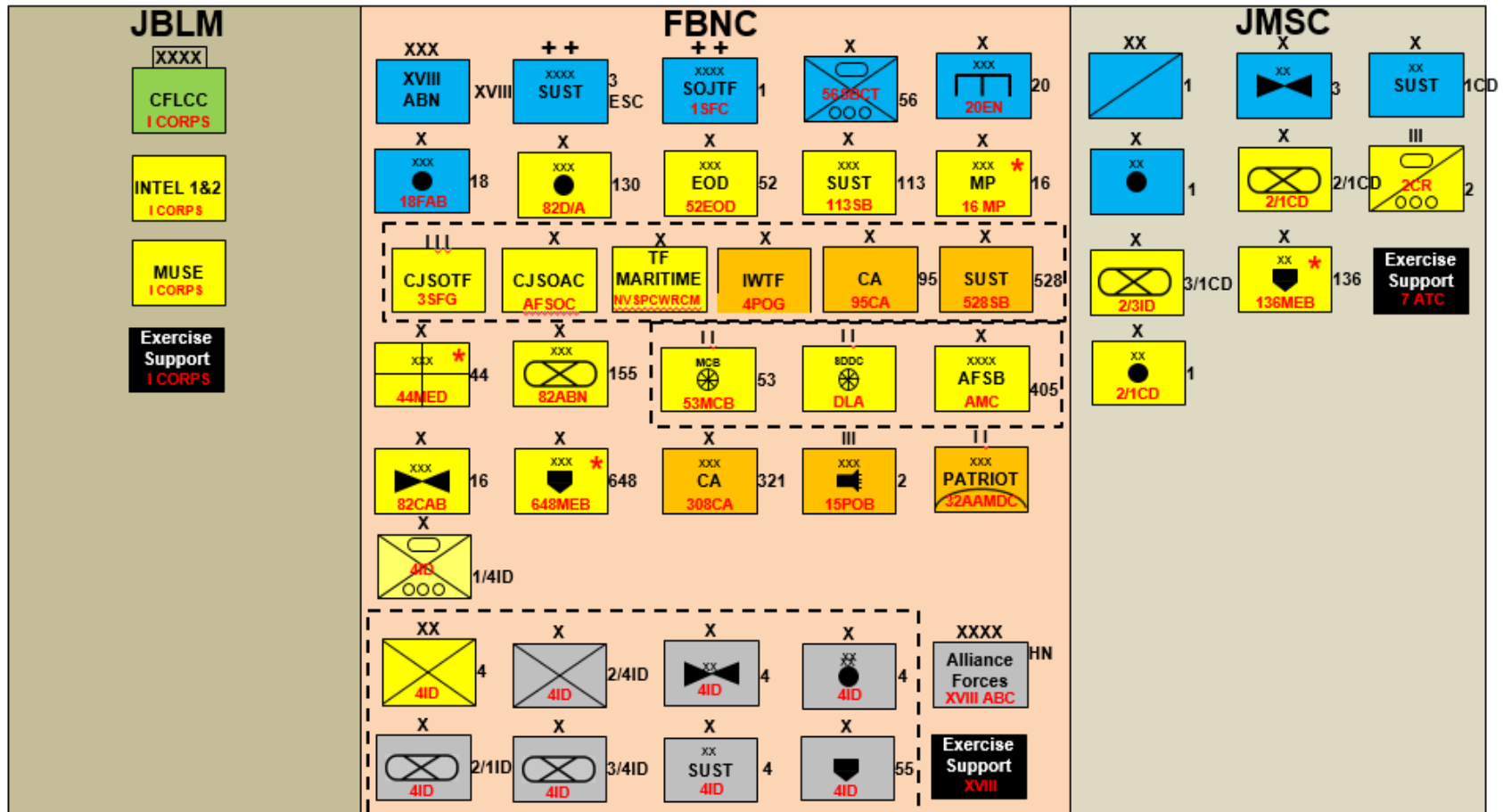

ECG MAIN

- ECG FWD
- OP'S GRP S (-)
- OP'S GRP A
- OP'S GRP B / F
- OP'S GRP C

- ECG FWD
- OP'S GRP B / F
- OP'S GRP D
- OP'S GRP S (-)

Legend:

- HICOM Cell
- TA / Work Cell
- Response Cell
- Functional Cell (embedded in other cell)
- MCC
- Scripted Only
- Ops Grp / ECG Or Support Detail
- Unit per Annex A
- Sourcing Unit
- Combined Cell
- Requires Sourcing
- * Enhanced RC w/ OC/T SPT



UNCLASSIFIED



UNCLASSIFIED

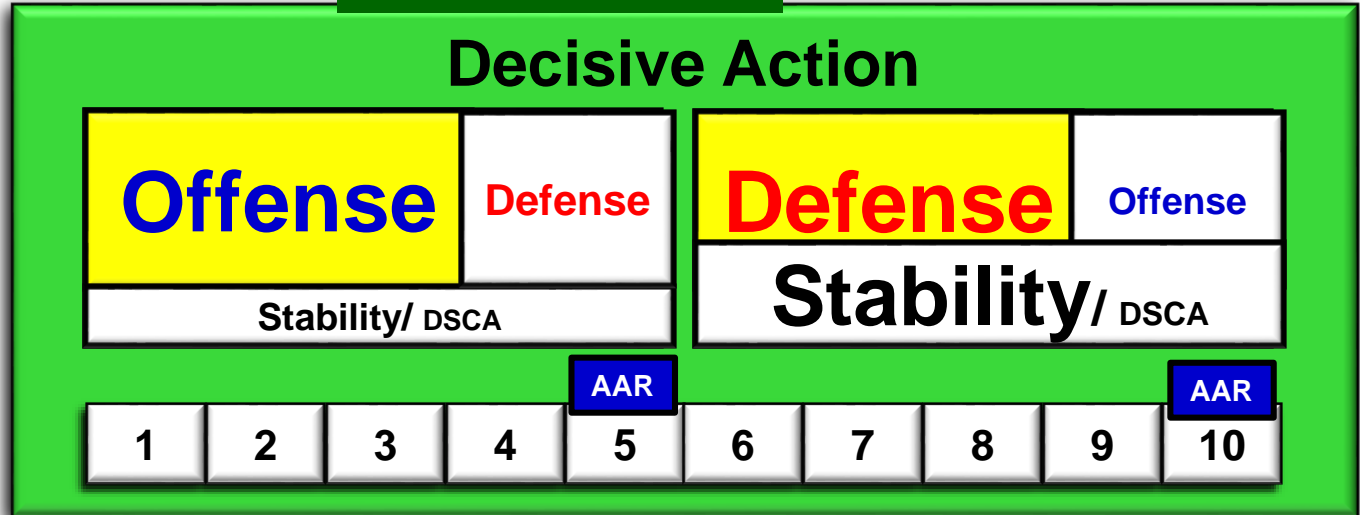
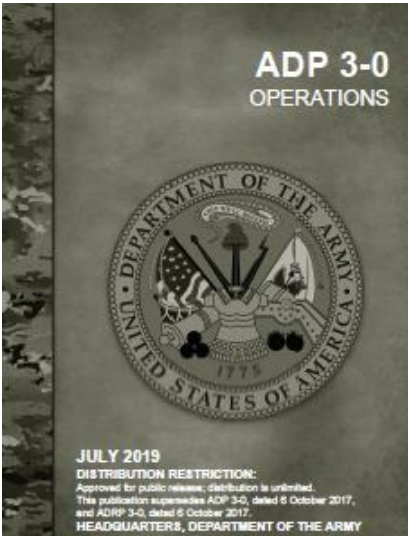

- Commander retains option to retrain tasks based on formal AAR feedback
- 8 days of training, with two formal AARs
- 24/ 7 continuous operations;
- Scenario follows OCONUS Unified Land Operations construct; seize, retain, exploit the initiative to gain and maintain relative position of advantage through Decisive Action—combinations of Offense, Defense and Stability tasks
- Modified to fit Commanders' Training Objectives and desires
- Dynamic Scripting of Scenario





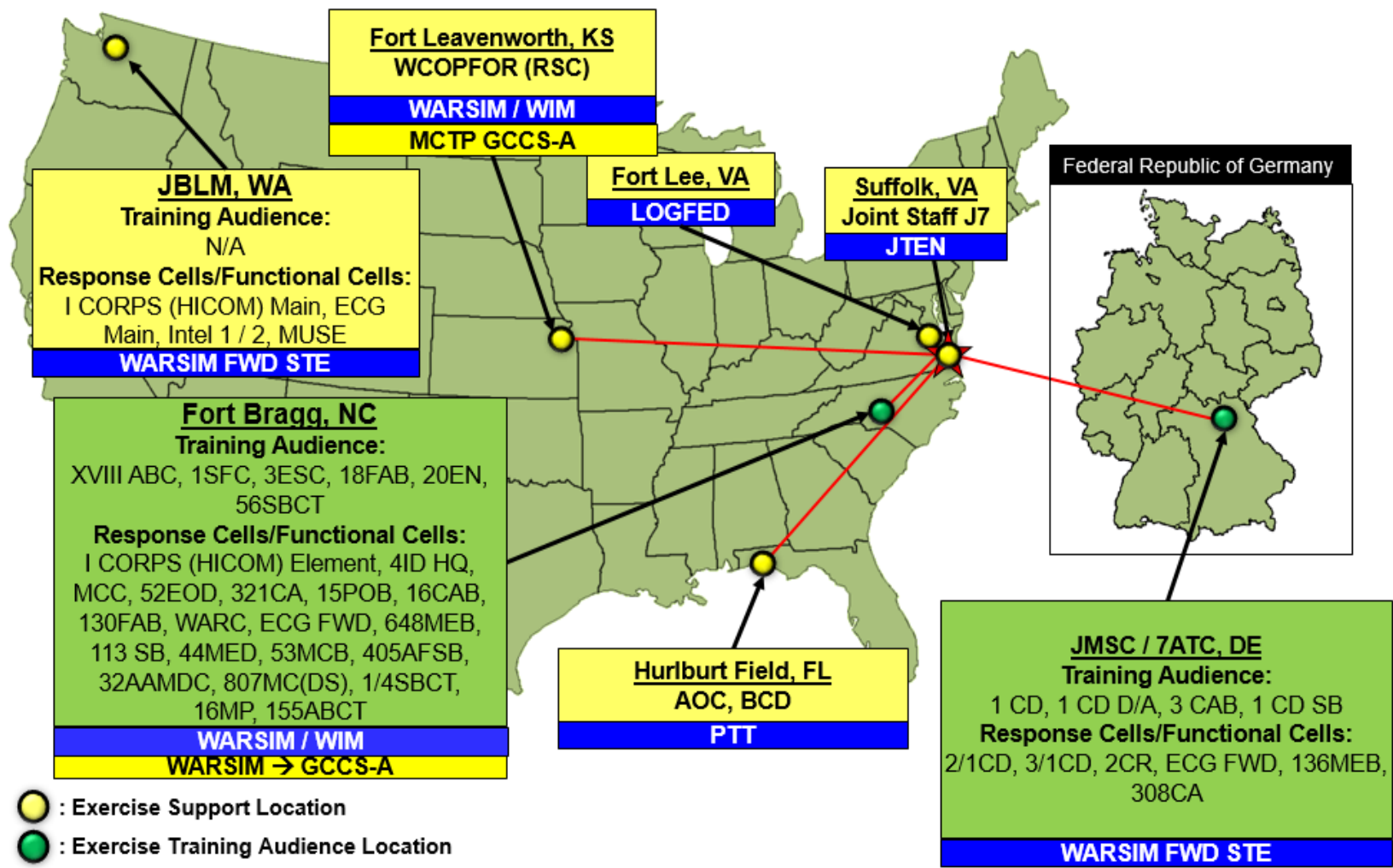





UNCLASSIFIED



- : Exercise Support Location
- : Exercise Training Audience Location
- : JTEN Connection
- : JTEN Control





-  Units who send decision makers to WFX planning events gain shared understanding and develop achievable training objectives
-  Units who participate in MCTP "Ride Along" programs are better prepared for their WFX and enter at a higher training proficiency
-  Units who understand their C4I systems, and those of their subordinate units, enter their WFX ready to communicate at echelon
-  Units who specially select Response Cell leadership and stabilize work station "*Pucksters*" meet more WFX training objectives
-  Units who send leaders and system operators to functional schools enter WFXs at higher levels of training proficiency
-  Units who actively seek and share WFX lessons from recent LSCO rotations enter WFXs at a higher state of training proficiency
-  Units who execute CPX 3 with MCTP augmentation (WCOPFOR, HQE-SM, and GSC) enter their WFX at higher readiness levels
-  Units who establish a Large Scale Combat Operations (LSCO) battle rhythms during CPX 3 are better prepared for WFX tempo





MISSION COMMAND TRAINING PROGRAM

"DECISIVE VICTORY!"

UNCLASSIFIED

FY 20 Exercise Calendar

UNCLASSIFIED

FY 20 MCTP Exercise Calendar

15 Jul 20

	OCT	NOV	DEC	JAN	FEB	MAR	APR	MAY	JUN	JUL	AUG	SEP
Exercise	WFX 20-1 01-10 OCT	WFX 20-2 12-21 NOV			WFX 20-3 05-14 FEB		WFX 20-4 01-10 APR		WFX 20-5 02-11 JUN			NTC 20-10 1 ID FRK S HOGG LAUGHLIN 12-27 Sep
EXDIR	JBLM	ROK-H			FBNC		JBLM		FRK S			
HICOM	LA1	VS			VS / J2		JBLM		VS			
OG-A	29 ID FTIG LUCKEIT GHONSKI 208 DLD	2 ID/RUCD ROK-H HOGG LAUGHLIN 48 CHEM ROK-H			25 ID SBHI LUCKEIT LAUGHLIN 244 DLD		XVIII ABC FBNC HOGG NOVALIS 207 DLD		25 ID FRK S HOGG NOVALIS 208 DLD			
OG-D	101 ABN FCKY HOGG VALCOURT 230 DLD		Y S 77 08-18 Dec USAR-J J1M		CORP S JBLM HOGG NOVALIS 144 DLD		CD ER LUCKEIT LAUGHLIN 830 DLD		25 ID FRK S HOGG NOVALIS 208 DLD			
OG-S	101 SB FCKY RICHARDSON 111 SB FTIG AKIN	19 ESC ROK-T RICHARDSON 2 SB ROK-T AKIN			593 ESC JBLM AKIN 25 SB SBHI CLOUGH		593 ESC FBNC AKIN 1 CD/ SB GER CLOUGH		77 B FRK S CLOUGH 4 B FRK S SB			
OG-F	101 CAB FCKY GOLDEN NOVALIS 77 ECAB FTIG WOLF	2 CAB ROK-H GOLDEN 8 MP SBHI CLOUGH			25 CAB SBHI GOLDEN 42 MP JBLM GHONSKI		CAB GER JLI 2 MEN FBNC WATSON		75 EN FRK S AKIN 14 E AB FRK S GOLDEN			
OG-B	101 D/A FCKY LONGO 142 FAB FTIG SEWARD	2 D/A ROK-H LONGO 210 FAB ROK-C SEWARD			25 D/A SBHI LONGO 17 FAB JBLM SEWARD		D/A GER LONGO 2 FAB FBNC SEWARD		25 MEB FRK S GHONSKI 2 FAB FRK S SEWARD			
OG-C	196 MEB JBLM WATSON	130 EN SBHI WATSON			26 MEB JBLM WATSON		56 SBCT JBLM WATSON		56 IBCT FRK S LAUGHLIN		79 IBCT FHLC LAUGHLIN 18-27 Apr	
OG-J	CJ SOTF HICOM Response Cell	CJ SOTF HICOM Response Cell			CJ SOTF HICOM Response Cell		15F CMD FBNC HEDOVICH		15 SFG FLK S HEDOVICH			

BLOCK LEAVE: 16 Dec 19 - 01 Jan 20

RESCHEDULED

BLOCK LEAVE: 27 Jun - 12 Jul 20

LEGEND

- = External OC/Ts
- * = Enhanced RC
- Italics* = PY 4
- Green Text = Div
- ◆ = MCP-OD

<p>RCs</p> <p>No MCTP OC/Ts</p> <p>218 MEB</p> <p>176 EN</p> <p>158 FAB</p> <p>157 MEB</p> <p>518 SB</p> <p>28 ID</p> <p>33 IBCT</p> <p>116 IBCT</p> <p>278 ABCT</p> <p>2/28 IBCT</p> <p>26 CA DDC</p> <p>12 POG</p> <p>20 CBRN</p> <p>65 MED</p> <p>201 CACOM</p> <p>14 POG</p>	<p>40 ID</p> <p>65 FAB</p> <p>16 CAB</p> <p>264 CA DDC</p> <p>11 POG</p> <p>303 MEB*</p> <p>555 EN*</p> <p>62 MED</p>	<p>4 ID</p> <p>135 MEB*</p> <p>648 MEB*</p> <p>266 CA DDC</p> <p>12 POG</p> <p>82 D/A</p> <p>16 MP*</p> <p>52 OD GRP</p> <p>3 SFG</p> <p>113 SB</p> <p>34 MED</p>	<p>36 ID</p> <p>25 IBCT</p> <p>256 IBCT</p> <p>155 ABCT</p> <p>169 FAB</p> <p>3 D/A</p> <p>300 MP</p> <p>141 MEB</p> <p>206 CA DDC</p> <p>10 POG</p>
--	---	---	--



MISSION COMMAND TRAINING PROGRAM

"DECISIVE VICTORY!"

UNCLASSIFIED

FY 21 Exercise Calendar

UNCLASSIFIED

FY 21 MCTP Exercise Calendar

23 Jul 20

	OCT	NOV	DEC	JAN	FEB	MAR	APR	MAY	JUN	JUL	AUG	SEP
Exercise	WFX 21-1 06-15 OCT	WFX 21-2 04-13 NOV			WFX 21-3 02-11 FEB		WFX 21-4 06-15 APR		WFX 21-5 06-15 JUN			
EXDIR	JBLM	FHTX			FHTX		FBNC		CAIN			
HICOM												
OG-A	XVIII ABCT PBNC Flagg/Roberts 3 BSC PBNC Dorman 28 IBN PBNC Waskan 18 MI* PBNC Laughlin 52 ABU PBNC Guchanan/ Thompson 52 SB PBNC TOD	4 ID MCOU TOD 200 DLD 4 SB PCOU TOD 4 DIA PCOU TOD 43 MI* F-11C TOD	Y8 7B 05-13 Dec USAIN-J J7N	BLOCK LEAVE: 19 Dec 20 - 03 Jan 21		1 ID HKS TOD 244 DLD 15B HKS TOD 1 DIA HKS TOD 16 CAB HKS TOD	COPT 21-1 6-10 Mar 8 Army WOK TOD AC 21-2 1-10 Mar USAIN/UKR Gbit TOD AC 21-2 1-10 Mar USAIN/UKR Gbit TOD	81 CUR/IS PHIX TOD 114 DLD 13 BSC PHIX TOD 73 FAB PHIX TOD 38 BN PHIX TOD 53 MI* PHIX TOD 3FR DIV 3UK DIV	JR 21 26 Apr-07 May USAIN/AF Gbit TOD	38 ID CAIN TOD 38 SB CAIN TOD 65 FAB CAIN TOD 23 SCAB CAIN TOD	BLOCK LEAVE: 26 Jun - 11 Jul 21	
OG-B	52 DIA PBNC Turner 52 CAB PBNC Car 1 CU PHIX Tucker 620 DLD 1 ACB PHIX TOD 1 CU DIA PHIX Largo 1 CU SB PHIX Richardson	28 ID F-11C TOD 113 SB F-11C TOD 180 FAB F-11C TOD 11 SCAB F-11C TOD 36 SBCT F-11C TOD				3 ID PSCA TOD 208 DLD 3 SB PSCA TOD 3 DIA PSCA TOD 3 CAB PSCA TOD 846 MdB PSCA TOD 48 BCT PSCA TOD	1 AU PHIX TOD 291 DLD 1 AU SB PHIX TOD 1AU DIA PHIX TOD 1AD CAB PHIX TOD	VR 21 26 Apr-07 May CSORC-GIT 7% CAIN TOD VR 21 26 Apr-07 May CSORC-GIT 4% CAIN TOD	38 ID ENHANCED RESPONSE CELL 316 BSC CAIN TOD 213 BN CAIN TOD 23 BCT CAIN TOD 44 BCT CAIN TOD			
SE	CJ BOTF HICOM Response Cell	10 SPC MCOU TOD					CJ BOTF HICOM Response Cell		CJ BOTF HICOM Response Cell			

EL 21
26 Aug-07 Sep (T)
ARCENT
JORDAN
TOD

LEGEND

○ = External OC/Ts
 ▲ = Enhanced RC
 Trailers = PY 4
 Green Text = Div
 ◆ = MCP-OD

34 ID
 128 MdB*
 128 MdB*
 142 MdB*
 32 DD CI*
 115 FAB
 3 ID
 180 CAB
 101 DIA
 52 CAB
 115 FAB
 204 MdB*
 55 MdB*
 118 ABCT
 211 BN
 29 ID
 32 CA
 72 BCT
 278 ABCT
 306 CA DOC
 12 POG
 1 AU
 200 SB
 21 MdB*
 278 MdB*
 180 CAB
 141 MdB
 67 MdB*
 180 FAB
 48 FAB
 29 CA DOC
 12 POG
 Decisive
 228 MdB*
 1CU SB
 202 MdB*
 180 CAB
 1 MdB
 48 CMEM*
 180 FAB
 381 CA DOC
 12 POG
 128 FAB
 32 BCT
 180 MdB
 180 MI*
 41 BCT
 101 ABCT
 180 CAB
 180 FAB
 284 CA DOC
 12 POG



Discussion

